

# Memorandum



**Date:** Wednesday, March 12, 2025

**Subject:** DR 2025000606

Applicant Name: Raising Cane's North Miami Beach

## PROJECT DESCRIPTION

The proposed Raising Cane's redevelopment will consist of a 3,181 square-foot fast-food restaurant with a drive-through window. The property, currently occupied by a 9,930 square-foot liquor store, will be demolished as part of the project. The impact of the proposed development is anticipated to reduce 118 net weekday PM peak-hour vehicular trips. Access to the site will be provided via three existing shared access points with the adjacent commercial property to the east: one left-in/right-in/right-out driveway located along the east side of SR-5/Biscayne Boulevard just north of NE 141st Street, one right-in/right-out driveway located along the east side of SR-5/Biscayne Boulevard just south of NE 143rd Street, and one full-access driveway located along the south side of NE 143rd Street, east of SR-5/Biscayne Boulevard. The proposed redevelopment is expected to be completed and opened by 2026.

## PROJECT LOCATION

The proposed redevelopment development is to be located at 14025 Biscayne Boulevard in North Miami Beach, Florida in unincorporated Miami Dade County.

## COMMENTS/RECOMMENDATION

**Miami-Dade County Department of Transportation and Public Works (DTPW) Traffic Engineering Division has reviewed the subject application and has no objections to this application, subject to the following conditions:**

1. According to the latest FDOT FDM manual Section 212.11.6, trees may not be placed within the hatched-out areas of the sight triangles, as shown in the figure below.

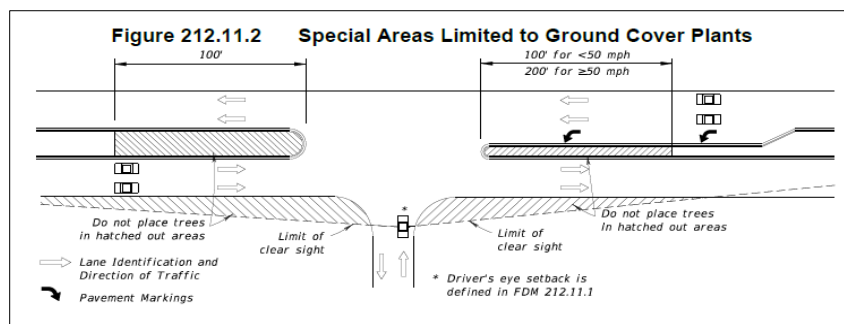

**If you have any questions concerning the comments, or wish to discuss this matter further, please contact Leanne Garcia Fernandez at (305) 439-6491**